

Reliability Improvement of Printed Circuit Boards by Designing Methods for Solder Joint Technical Diagnostics with Application of Acoustic Emission Method

Kovtun I. I., Boiko J. M., Petrashchuk S. A.

Khmelnytskyi National University

E-mail: *boiko_julius@ukr.net*

The paper represents technical diagnostics of printed circuit boards in particular their solder joints performed by commonly used through-hole and surface mount technologies. Operation and technology cause mechanical interactions and forces between substrate of printed circuit board and electronic components. Such tensile, shear, bending or torque forces transmit through the contact joints, which appear to be the weakest links in the assembly. The experimental research was conducted by mechanical tensile and pure bending tests followed by using method of acoustic emission. Conducted tests demonstrated considerable sensitivity and applicability for the method of acoustic emission to detect defects and possibly to assess the ultimate strength of solder joints in nondestructive diagnostics performed under forces long before the final failure. In order to minimize errors while measuring small loads in tensile tests of ceramic capacitors the special appliance was designed. The experiment was conducted to verify the overheating effect to ultimate load of the solder joints. Surface mount technology for ceramic capacitors has been optimized by introducing high temperature preheating mode that improves adherence to the contact pads and increases tensile strength, what was also confirmed by acoustic emission analysis. The pure bending appliance was designed to provide instant monitoring of all solder joints by equal testing stress. By conducted pulsing test cycles the total count was identified as the most informative parameter of acoustic emission that correlates with types of defects and ultimate strength of the solder joints. The planar location model has been developed by the idea of remote detection of acoustic emission through the volume of homogeneous medium such as water, unlike detecting acoustic emission on the surface of printed circuit board where acoustic emission signal is likely to be distorted or even lost. Using method of acoustic emission and pure bending cycling test the method for technical diagnostics of solder joints has been designed. The results represented in the paper contribute to design and technology improvement in radio-electronics.

Key words: solder joint; printed circuit board; technical diagnostics; electronic component; acoustic emission; tensile test; pure bending

DOI: [10.20535/RADAP.2019.79.60-70](https://doi.org/10.20535/RADAP.2019.79.60-70)

Introduction

Modern trend to manufacture ever smaller mechanical, optical and electronic products and devices compromises quality and reliability standards of their components. Printed circuit boards (PCB) are considered the main building blocks of modern electronics, which represent assemblies purposed to electrically connect and, what is also important, mechanically support electronic components. However operation and even technology cause mechanical interactions and forces, acting between PCB substrate and electronic components, and spreading through their links. Such tensile, shear, bending or torque forces cause strain and stress in substrates, which are subsequently transmitted to bodies of components through the contact

joints, which appear to be the weakest links in the assembly. The damages of the joints cause failures of the whole electronic units and therefore require detailed studying [1–6].

The general technology for component installation onto the PCBs remains soldering although quality of soldered joints (SJ) is not always achievable due to numerous defects. One of the approaches capable to provide quality and reliability for SJs is to apply and improve their testing methods. Despite existing of the wide range of methods for non-destructive or destructive SJ tests provided by the state standard [7–9] they do not always provide proper quality selection and control. Such methods use measuring electric (resistance), electrically parametric (amplitude frequency response) or physical parameters for quality control of

SJs but their application appears to be either expensive and or not efficient to detect and assess defective SJs. In nowadays the approach based on using nondestructive quality diagnostics and in particular method of acoustic emission gains its popularity.

Solder joints studied in the represented research were performed by two commonly used technologies: through-hole technology (THT) and surface mount technology (SMT) [10, 11]. The experimental research was conducted by using mechanical tensile and pure bending tests simultaneously with method of acoustic emission with recording acoustic emission parameters against applied forces and mechanical characteristics in order to find relationship between parameters of acoustic emission and such defects of solder joints as cold joint and low solder adhesion.

1 Through-hole technology solder joints tensile test and defect detection

Solder joints of MLT2 resistors made by THT technology were the objectives for the research. The research was conducted in progress of strain analysis presented in [12, 13] and aimed at assessing SJs strength by using tensile tests and acoustic emission method.

In order to assess parameters of acoustic emission signals against types of defects and find their possible correlation tests were performed for solder joints, part of which was soldered with implemented defects.

The experiment was performed by static mechanical tensile testing on soldered joints of MLT-2 resistors. Resistors were installed on PCB by THT technology into 2 mm contact pads. The tensile testing machine IP-5057-50, which has 500 N ultimate force capacity and 1% measurement tolerance provided uniaxial tensile testing. To perform the test one lead of each resistor had been soldered to metallized hole in PCB with tin-lead alloy and fixed in the upper clamp of tensile machine. Concurrently the PCB substrate was firmly fixed in the custom lower clamp of the machine. Thus the soldered joint was subjected to uniaxial tensile test between lead and PCB substrate to provide the most unfavorable load to the joint that pulled the lead out of the metallized hole in PCB substrate [6, 14, 15].

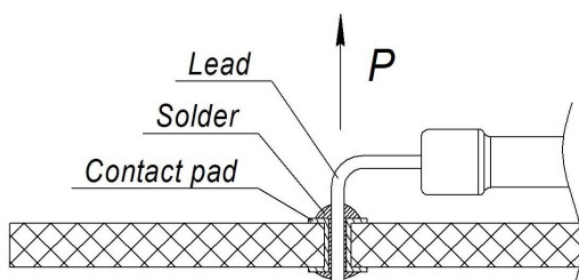

Fig. 1. Uniaxial tensile test on the solder joint

Sixty solder joints prepared for the test represented three groups: 20 SJs without defects; 20 SJs had “cold solder” defects; 20 SJs had “low solder adhesion” defects. The testing force was applied with the constant speed at 0.1 mm per minute. During this process, the acoustic emission parameters were recorded against the applied force. AE parameters were: amplitude; activity; total count [16, 17].

The acoustic emission research was performed by measuring system designed on the base of instrument AF-15, which had been modified in order to connect it to computer and thus 40 times increase the data rate recorded. Acoustic emission signals were detected by piezoelectric resonant transducers (gauges) P113 with 0.2-2.0 MHz frequency band and 1.6×10^9 V/m conversion factor. Piezoelectric gauges are connected to preamplifiers with 40 dB amplification gain. Preamplifiers transmit signals to amplifier and filter unit, which provides discrete selection of amplification gain and frequency diapason within the frequency range from 20 kHz to 2 MHz. The data rate is specified for the following parameters: total count – $10^0 - 10^6$ imp.; activity – $10^0 - 10^3$ imp/sec; dynamic diapason of amplitude – 150–5000 mV.

The lowest ultimate tensile strength was measured for low adhesion joints. Solder joints with such defects sustained only 30-40 N. The failure of these joints occurred when the leads were pulled out of the solder with no acoustic emission detected. As far as the case when leads are not wetted completely in the solder joint is very unlikely, further testing on SJs was carried out on specimens having partly wetted leads. Such tests resulted in ultimate strength of 70-80 N [18–22].

The averaged results of the experiments are given in table. 1. Statistical analysis of experimental data testified the significant decreasing ultimate strength for defective SJs with 95% confidence probability.

Table 1 Tensile tests results for soldered joints of 60 resistors MLT 2

Group	Solder joint condition	Average ultimate load, N	Average strength decrease, %
1	Joint without defect	116.2	–
2	Cold joint	44.5	62
3	Low adhesion joint	75.9	35

In analysis of AE parameters, recorded along with the load progression, two parameters were considered to be the most informative: total count N (impulses, imp) and maximal activity A_{max} (impulses per second, imp/s). The comparative analysis was made among three types of solder joints for acoustic emission parameters recorded within the force range from 0 to 44 N what corresponds to average ultimate strength for

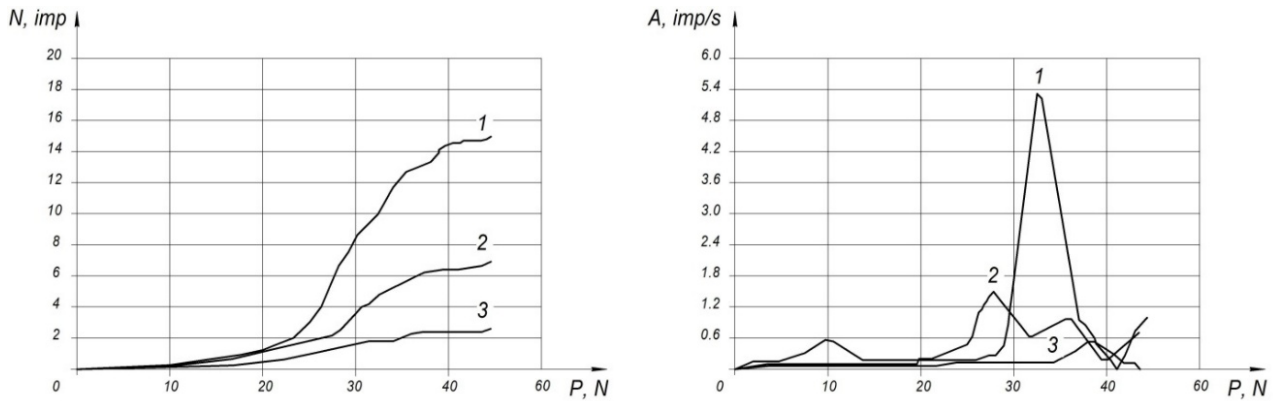

Fig. 2. Acoustic emission parameters against force progression recorded during tensile tests on solder joints of three types: 1 – cold joints; 2 – low solder adhesion joints; 3 – solder joints without defects

the cold joints and makes 40 % of the ultimate force for joints without defects (table. 2, fig. 2).

Table 2 Acoustic emission parameters under 40 % of the solder joint ultimate tensile force

Group	Solder joint condition	Total count, imp	Maximal activity, imp/s
1	Joint without defect	34	51
2	Cold joint	70	210
3	Low adhesion joint	22	40

As foreseen, the AE character differed for different groups. Fig. 2 demonstrates acoustic emission progression recorded against the applied force during tensile tests on solder joints in three groups with mentioned types of defects.

Obtained results can testify of substantial sensitivity and applicability for the method of acoustic emission to detect defects and possibly to assess the ultimate strength of solder joints. Besides, it holds the potential for nondestructive diagnostics of solder joints which is performed with the help of mechanical tests under forces long before the final failure [23–25].

2 Surface mount technology solder joints tensile strength assessment and technology improvement

The metallic ceramic capacitors K10–17B and K10–50B, which are surface mount devices (SMD), were objectives for the next research. Nowadays SMD technology gains popularity due to range of advantages before THT. Exploring, assembling and testing these capacitors are likely to cause damages in form of contact pads defoliation and detachments or even

capacitor destruction [4]. Preliminary shear strength tests revealed that ultimate shear loads 2–4 times exceed tensile ones. Therefore capacitors K10–17B and K10–50B were subjected to the tensile tests aimed at defining: ultimate loads that cause mentioned damages; tensile strain of capacitors; difference in ultimate loads for overheated solder and cold solder joints of K10–50B capacitors; correlation between AE signals and solder joint strength for varied technological conditions.

In order to minimize errors in measuring small loads for tensile tests the special appliance was designed (fig. 3).

The measuring train used in the test consisted of electro-tensometry and acoustic emission instruments. Two batches of 100 capacitors K10–17B and K10–50B were tested. Capacitors 5 (fig. 3) were soldered by their termination caps to the ends of two strips, cut out of the PCB substrate, which were then clamped in between the lever 3 and the base 1. Turning handle 8 revolved the drum 7 and through the traction 6 pulled the left side of the lever 3 so as to apply load to capacitors; load was indicated by dynamometer 4. To increase measurement accuracy for smaller loads the testing appliance is designed so that lever shoulders can be varied if needed.

Tests were conducted with simultaneous records of acoustic emission and loads. In all the cases destruction occurred as defoliation of a contact pad. Strain gauges were attached to capacitors (fig. 3) with purpose to define strain versus load dependences (fig. 4). The average ultimate loads measured for batches of capacitors K10–17B and K10–50B made $P_1 = 23.7N$ and $P_2 = 31.8N$ correspondently.

The next experiment was conducted to verify the overheating effect to ultimate load of solder joints. Two groups of capacitors K10–50B that differed in soldering technologies were subjected to tensile tests.

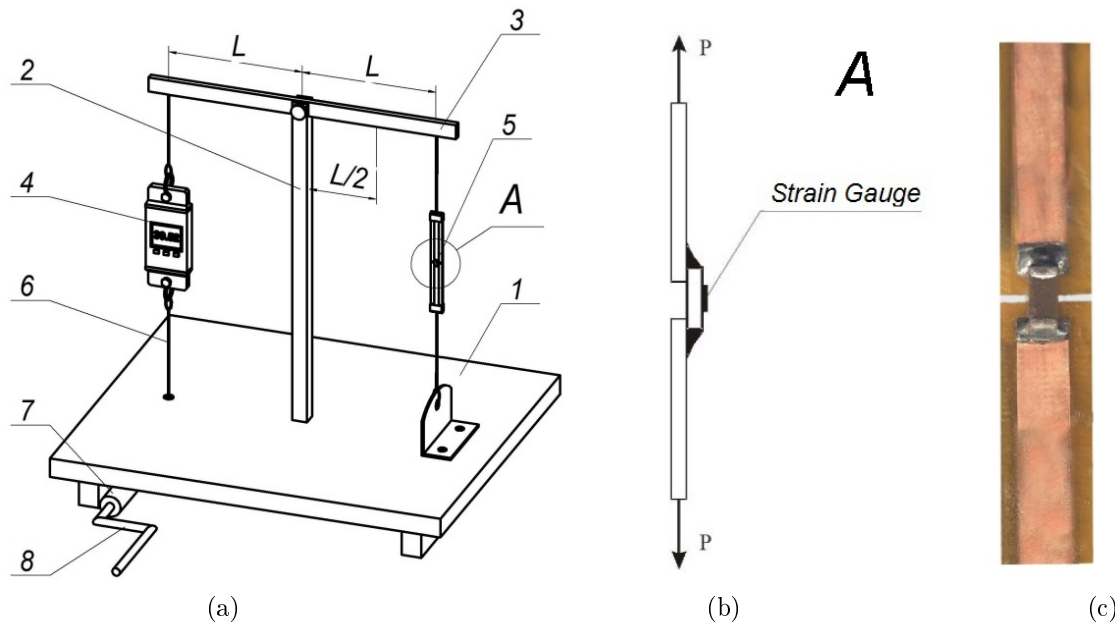

Fig. 3. Manual tensile test appliance: a – structure; b – strain gauge attachment; c – capacitor installation. 1 – base; 2 – support; 3 – lever; 4 – dynamometer; 5 – capacitor; 6 – traction; 7 – drum; 8 – handle.

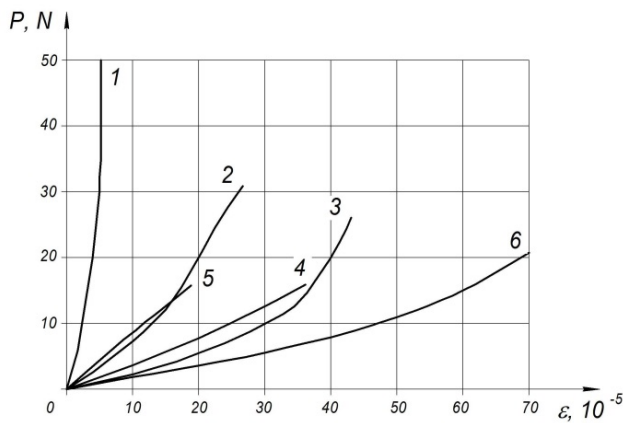

Fig. 4. Strain versus tensile load dependences for capacitors K10-17B (1) and K10-50B (2,3 - 6)

In the first group soldering was conducted at 220-270°C temperature during 10 sec with standard alloy POS-61, in the second group – at 94-120°C temperature with rosin alloy.

Data analysis (table. 1) testified that overheating of solder joints improves their adherence to the contact pads and increases their tensile strength.

Significant difference between cold solder and overheated joints was indicated by acoustic emission recorded (fig. 5) during experiment. For the cold solder AE signals appeared earlier; their total count was 1.5 times and activity – 2.5 times higher than for overheated ones. Average strains recorded for cold solder and overheated joints were $\epsilon_1 = 70 \times 10^{-5}$ and $\epsilon_2 = 45 \times 10^{-5}$ correspondently.

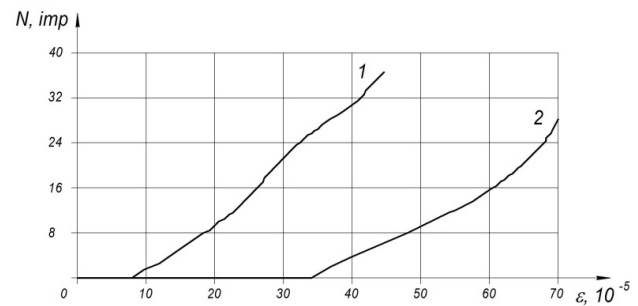

Fig. 5. Acoustic emission total count versus strain diagrams: 1 – cold solder joints with ROSE alloy; 2 – overheated joints with POS-61alloy

The next experiment was made with conjecture that contact joint strength depends on soldering temperature. The experiment was arranged with account for limitations posed by complexity to measure solder temperature either theoretically or practically. The decision was made to remain soldering technology unchanged with an exception for contact joint temperature, which was considered to increase by preliminary heating the capacitors [26, 27].

The experiment was conducted for two groups of capacitors. 1st group was soldered at the standard temperature. 2nd group was preheated before soldering in thermostat within 1 hour at the discrete temperatures: 150°C; 180°C; 200°C, 215°C, 230°C, 250°C. After preheating capacitors were soldered and subjected to tensile tests by the method explained above.

Data analysis (table. 3) indicated that preheating of solder joint at 200°C increased its strength by 50%. Moreover optimal preheating temperature, producing

Table 3 Tensile ultimate loads of K10-50B capacitor solder joints for different temperature modes

Soldering technology modes					
Duration: 10 sec			Duration: 3 sec		
POS 61 $t = (220 - 270)^\circ\text{C}$	rosin alloy $t = (94 - 120)^\circ\text{C}$	Standard	Preheated in thermostat within 1 hour at the temperatures, $^\circ\text{C}$:		
			150	200	250
Average tensile ultimate loads, N					
59.7	36.2	30.6	40.3	47.6	22.9

maximal strengthening effect was defined in interval of 180-200 $^\circ\text{C}$.

3 Theoretical model of pure bending condition for printed circuit boards

Conducting tensile tests with simultaneous recording acoustic emission showed perspectives for nondestructive strength diagnostics of components solder joints installed on PCB, although practical application of the method was limited by monitoring only the single component joints at the time. In order to overcome this limitation and conduct tests for entire PCB with all components installed the pure bending technique was applied (fig. 6) [28,29]. The pure bending was designed to provide equal testing stress over the PCB area as applied in between two supports. Using such technique allows monitoring all solder joints present within the tested area simultaneously.

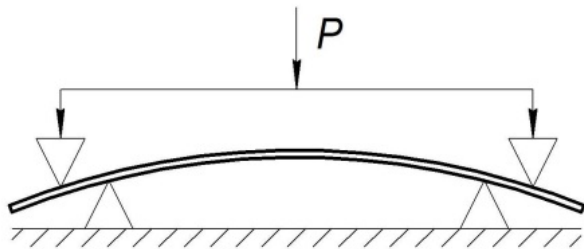

Fig. 6. Pure bending test on printed circuit board

The experimental tests were conducted on PCBs populated with surface mount devices whose solder joints were now the research objectives. The threshold limit force applied during bending test was to be specified in order to provide necessary stress for the tested joints. Noteworthy is that ultimate strength of a solder joint depends on its mechanical characteristics which are to be found with respect to its design and technology. Thus, the ultimate strength of the solder itself is less than strength of the solder joint it makes. For an instance the ultimate strength for the solder POS40 in the cast phase makes $\sigma_u = 40$ MPa and ultimate strength for the fiberglass substrate is $\sigma_u = 45 - 100$ MPa [6].

Assuming ultimate strength of the solder as the reference value the test stress is calculated by the

formula:

$$[\sigma] = \frac{\sigma_u}{n} = \frac{40}{2.5} = 16 \text{ MPa}, \quad (1)$$

where σ_u – ultimate strength, $n = 2.5$ – safety factor.

Using formula (1) ensures that possible error in calculations caused by no account for design and technology of the joint will deposit into the safety factor. Safety factor used in the formula is sufficient to ensure safe level of testing stress σ_{test} which is within proportionality strain area of solder material. Under such stress the material of solder undergoes only elastic deformations, which do not reduce its strength.

The testing stress is used to specify the threshold limit force P , which is to produce the nondestructive tests on solder joints. The force application scheme is represented in fig. 7.

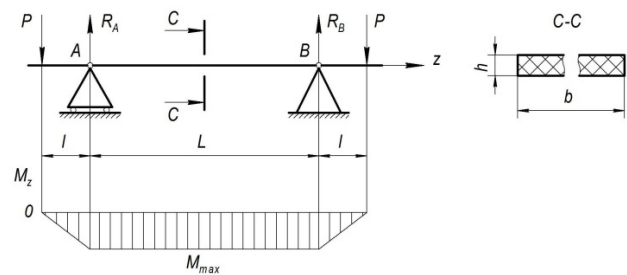

Fig. 7. Force application and internal bending moments diagram for pure bending test on printed circuit board

According to fig. 7 the maximal and equal moments $M = M_{max}$ appear only in pure bending area with the length L which is created by and lays in between two supports A and B , and the stress they generate is maximal in peripheral layer on the PCB cross section $C - C$ [6]. The upper layer on the height h elongates and undergoes tension and the lower layer shortens and undergoes compression stresses. Then the maximal stress is found by formula:

$$\sigma_{max} = \frac{M_{max}}{I_{ax}} y_{max}, \quad (2)$$

where M_{max} – maximal bending moment created by action of the force P ; I_{ax} – axial moment of inertia; y_{max} – maximal distance from the neutral line of the cross-section to the peripheral layer (fibers); $y_{max} = h/2$, where h – thickness of the printed circuit board substrate.

Understanding that ratio I_{ax}/y_{max} represents the axial moment of resistance W_{ax} , formula (2) will be

shortened as:

$$\sigma_{max} = \frac{M_{max}}{W_{ax}}. \quad (3)$$

According to strength condition for normal stresses which are created by the bending force – maximal stress has to comply with acceptable standard [7]:

$$\sigma_{max} \leq [\sigma]. \quad (4)$$

In order to perform nondestructive test on PCB in compliance with acceptable standard requires maximal acceptable force estimation [6].

According to force application scheme (fig. 7) and by using formulas (3) and (4) the maximal bending moment is expressed as:

$$M_{max} = P \cdot l, \quad (5)$$

axial moment of rectangular section resistance [6] is expressed as:

$$W_{ax} = \frac{b \cdot h^2}{6}. \quad (6)$$

Then maximal acceptable force to be applied for nondestructive bending tests on PCB, has to comply with condition:

$$[P] \leq \frac{b \cdot h^2}{6l} [\sigma]. \quad (7)$$

4 Printed circuit boards pure bending strength test

Pure bending tests conducted by using tensile machine IP-5057-50 indicated that the activity of acoustic emission responds to the loading speed. Since AE data analysis requires its essential amount the decision was made to conduct tests at maximal acceptable force application speed, which was 100 millimeters per minute. The applied force was under acceptable level calculated by formula (3) $P_{test} = 36N$. However even such force application indicated negligibly low activity of acoustic emission yet so the test was continued in cycling mode of multiple loads and unloads. All PCBs were tested in five cycles. In such pulsing cycles stresses in solder joints caused by the force application ranged from 0 to 16 MPa. Acoustic emission parameters recorded during all tests were received to from piezoelectric gauges and pre-amplifiers at 0.02-0.2 MHz frequency band. Piezoelectric gauges were attached to PCB surface through the layer of acoustic paste [30, 31].

The tests were performed for 60 double sided foil laminated fiberglass printed circuit boards (dimensions: $320 \times 120 \times 1.5 \times 0.1$ mm). For the experiment PCBs were prepared and sorted into three equal groups which differed in defects embedded into their solder joints: 1) PCBs with solder joints without defects; 2) PCBs with cold joints; 3) PCBs with low solder adhesion joints. Solder joints taken for the tests were created

on each PCB by installing one component – resistor MLT-2. Through-hole technology was used. For the group 1 installation technology sustained technological standard [28]. In the group 2 one of the leads of resistors was soldered with cold joint defect, which is recognized as “circle crack” joint and is likely to occur in THT. In the group 3 solder joints were embedded by low solder adhesion defect; such defect was reproduced by performing incomplete solder technology – in this purpose leads were not wetted by solder before the actual soldering.

The acoustic emission parameters were recorded against the applied force. AE parameters were: amplitude; activity; total count. Analysis of acoustic emission data obtained for three groups of PCBs indicated the following. PCBs of the first group, which had no defects embedded into their solder joints, did not radiate considerable acoustic emission during all cycles unlike the other groups. PCBs whose solder joints had low solder adhesion defects radiated acoustic emission the reached 10-15 imp total count and 1 mV amplitude. Such signals were observed at load progression phase of the cycles and in peaks of the force. Another group of PCBs with cold joint defects was characterized by considerably higher values of acoustic emission parameters: total count reached 30-40 imp with 2.5 mV amplitude. Moreover the character of acoustic emission for the cold joints was specific – acoustic emission appeared on the load discharging phases of the cycles, what may demonstrate the process when cracks present in the joint are converging their edges. The examples of acoustic emission diagrams obtained during pure bending cycling tests on PCBs with embedded solder joint defects are shown in figures 8,9.

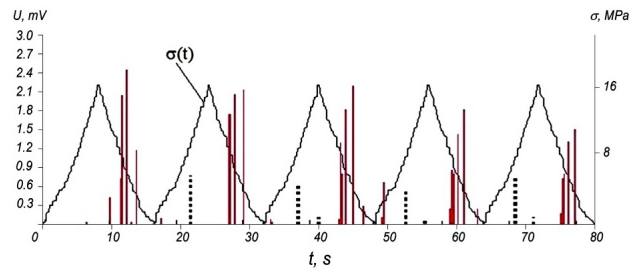

Fig. 8. Acoustic emission amplitude diagram in 5 pulsing cycles of pure bending test: dash lines – low solder adhesion joints; solid lines – cold joints

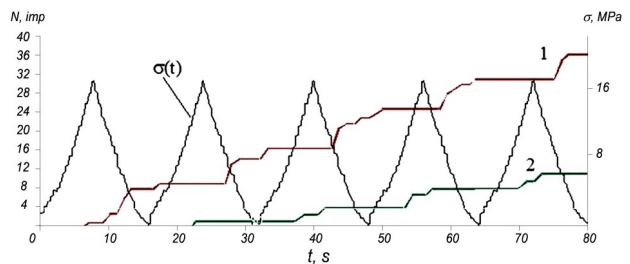

Fig. 9. Acoustic emission total count in 5 pulsing cycles of pure bending test: 1 – cold joint; 2 – low solder adhesion

The obtained records of acoustic emission parameters against the force applied and their assessment allowed to select the total count as the most informative parameter that correlates with types of defects and, what is more practicable, with ultimate strength of the solder joints. Thus application of acoustic emission method along with mechanical tests and recognizing acoustic emission character correlation with mechanical characteristics of the solder joints, such as ultimate strength, gives the reason to use it for developing strength diagnostic methods of PCB's solder joints [4, 24, 25].

5 Theoretical model and implication of planar defect location in printed circuit boards

The location accuracy of acoustic emission is strongly effected by acoustic characteristics of the transmitting medium and becomes complicated problem for a medium which is heterogeneous. So AE spreading and location in PCBs is strongly complicated due to structural complexity of PCBs, that consist of THT or SMD components, conductive tracks, pads and other features etched from copper sheets laminated onto a non-conductive substrate, whose acoustic characteristics (table. 4) are different [26]. The task of the current research was to develop method for planar location of AE whose sources are defects progressing in stressed PCBs when exposed to external forces.

Material Density

The idea of the method developed for planar location consisted in remote detection of AE by piezoelectric transducers through the volume of homogeneous medium [19, 28, 29] such as water, unlike detecting AE on the PCB surface where AE signal is likely to be distorted or even lost. Water retains the most acceptable attenuation constant $\delta = 2.5$ as compared to other homogeneous mediums.

The testing installation represents load appliance for PCBs and 4 piezoelectric sensors installed insi-

de the water chamber. PESs were installed on the plane parallel to PCB at the specified distance, so that their receiving side faced the tested PCB. Acoustic waves generated by defects in PCB spread through the volume of water and reach the sensors with negligible loss or distortion.

The planar location in Cartesian coordinates is calculated in the space coordinate system XYZ. 4 PESs are installed on the axes X and Y in $z = 0$ plane (fig. 10).

The monitored PCB lays in the plane $z = zK$, where zK is distance between the PCB and PESs. The 4 channel acoustic emission system detects two time differences τ_1 and τ_2 of signal arrivals to two pairs of opposite sensors in two orthogonal axes. Time differences τ_1 and τ_2 is related to distance differences from AE source K to PESs in correspondent pair:

$$\begin{cases} BK - AK = \tau_1 \vartheta, \\ CK - DK = \tau_2 \vartheta, \end{cases} \quad (8)$$

where τ_1 – time difference of signal arrivals to PESs in points A and B; τ_2 – time difference of signal arrivals to PESs in points C and D; ϑ – ultrasonic speed in water.

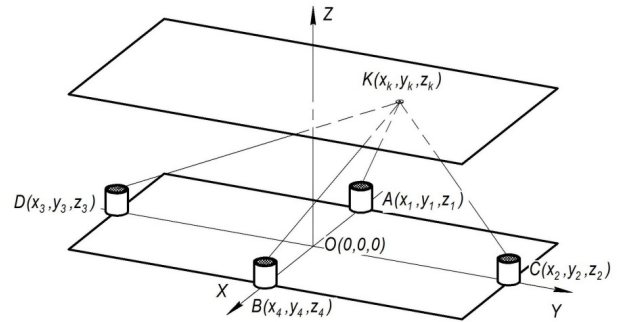

Fig. 10. Planar location scheme in acoustically transparent medium: K – source of AE; A, B, C, D – piezoelectric sensors

The final expressions for AE coordinate calculation are represented as:

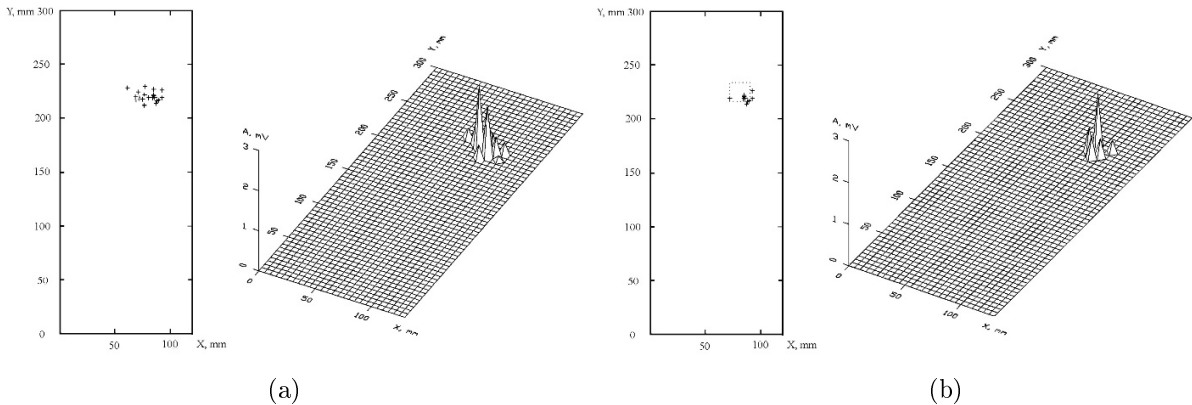

Fig. 11. Acoustic emission planar diagrams recorder during PCB bending tests: a – location on PCB surface; b – location in acoustically transparent medium

Table 4 Acoustic characteristics of PCB structural materials

Material	Density $\rho \cdot 10^3$, kg/m ³	Wave speed $v \cdot 10^3$, m/s			Attenuation constant δ, m^{-1}
		Longitudinal	Cross	Surface	
Textolite	1.2–1.3	2.63	–	–	> 100
Lead	11.4	2.16	0.70	0.63	1–10
Copper	8.9	4.66	2.26	2.12	10–100

$$\begin{cases} x_k = \pm \frac{1}{2} \sqrt{\frac{\tau_1^2 \vartheta^2 \tau_2^2 \vartheta^2 (\tau_2^2 \vartheta^2 - \tau_1^2 \vartheta^2 + 4x_4^2 - 4y_2^2) + 4\tau_1^2 \vartheta^2 y_2^2 (\tau_1^2 \vartheta^2 - 4x_4^2 - 4z_k^2)}{4\tau_1^2 \vartheta^2 y_2^2 + 4\tau_1^2 \vartheta^2 x_4^2 - 16x_4^2 y_2^2}}, \\ y_k = \pm \frac{1}{2} \sqrt{\frac{\tau_1^2 \vartheta^2 \tau_2^2 \vartheta^2 (\tau_1^2 \vartheta^2 - \tau_2^2 \vartheta^2 + 4x_4^2 - 4y_2^2) + 4\tau_2^2 \vartheta^2 x_4^2 (\tau_2^2 \vartheta^2 - 4y_2^2 - 4z_k^2)}{4\tau_1^2 \vartheta^2 y_2^2 + 4\tau_2^2 \vartheta^2 x_4^2 - 16x_4^2 y_2^2}}, \end{cases} \quad (9)$$

In formulas (9) positive or negative signs are selected regarding signs of τ_1 and τ_2 .

The experimental verification of the offered method was conducted in testing installation with PESs installed at 70 mm distance from the tested PCB. The AE planar location diagrams obtained by regular surface location performed on the PCB surface and by the developed method are shown in fig. 11 (a) and fig. 11 (b) correspondently.

The application of developed method in acoustically transparent medium indicated that located area of the spotted defect makes about 1 % of the total PCB area, what provides accuracy 2-4 time higher than by the regular surface location.

6 Method for technical diagnostics of solder joints with application of acoustic emission method

Conducted research and results of application of acoustic emission method in mechanical tests on printed circuit boards allowed to design method for technical diagnostics of printed circuit boards and their solder joints.

Technical diagnostics of solder joints is performed by the following steps.

- The test on printed circuit boards are conducted by pure bending force application under acceptable limit of the load estimated with respect to the safety factor for the solder material $n = 2.5$.
- In case when acoustic emission is detected, the test is repeated in 5 load/unload pulsing cycles. Progression of acoustic emission (total count) in the cycles indicates of defect progression in the solder joint and such PCB is rejected and classified as defective.
- When required defect location is performed in order to repair it.

The developed method has been tested out on the batch of industrial printed circuit boards [9]. The tests

were conducted for 32 single sided fiberglass foil laminated PCBs (dimensions: 120 × 140 mm). During the tests three PCBs were detected by observing acoustic emission radiate, what indicated a process of defects progression. Analysis of the acoustic emission character helped recognize the type of the detected defects – low solder adhesion, which was then identified by detailed optical 10x zoom revision of the places where AE was spotted. The solder joints were also examined by measuring their electric resistance what confirmed the previous conclusion. Noteworthy is that PCBs taken for tests had been used for a long time and detected defects had remained hidden before the tests. Hence, these defects could have potentially progressed if PCBs had operated furthermore and such solder joints would have failed causing failure of the whole electronic unit.

Conclusion

Experimental research conducted for solder joints performed by through-hole and surface mount technologies on printed circuit boards by using mechanical tensile and pure bending tests along with method of acoustic emission with simultaneous monitoring both mechanical characteristics and acoustic emission parameters resulted in finding relationship between parameters of acoustic emission, in particular total count, and such defects of solder joints as cold joint and low solder adhesion.

The experimental research by tensile tests has verified the overheating effect to solder joints, as long as the overheating of solder joints improves their adherence to the contact pads and increases their tensile strength, and demonstrated applicability of acoustic emission method capable to indicate significant difference between cold solder and overheated joints.

The theoretical model for pure bending testing on printed circuit boards has been developed in order to provide equal testing stress condition over the printed circuit board and calculate maximal acceptable force to be applied for nondestructive bending tests.

Theoretical model for planar location has been developed for defect location in printed circuit boards. The application of developed method in acoustically transparent medium indicated that located area of the

defect makes about 1% of the total PCB area, what provides accuracy 2-4 time higher than that by the regular surface location.

Method for technical diagnostics of solder joint on printed circuit boards that uses pure bending cycling tests with application of acoustic emission method has been designed.

References

- [1] Tong J.P.C., Tsung F., Yen B.P.C. (2004) A DMAIC approach to printed circuit board quality improvement. *The International Journal of Advanced Manufacturing Technology*, Vol. 23, Iss. 7-8, pp. 523-531. DOI: 10.1007/s00170-003-1721-z
- [2] Liu X. and Fang W. (2011) Life character analysis methods of storage electronic components. *2011 International Conference on Quality, Reliability, Risk, Maintenance, and Safety Engineering*. DOI: 10.1109/icqr2mse.2011.5976773
- [3] Barto S. and Mach P. (2016) Nonlinear distortion of C/V characteristic — Useful tool for diagnostics of electrically conductive adhesives: Theoretical background, measuring equipment, selected applications. *2016 Conference on Diagnostics in Electrical Engineering (Diagnostika)*. DOI: 10.1109/diagnostika.2016.7736501
- [4] Kovtun I., Boiko J., Petrashchuk S. and Kałaczyński T. (2018) Theory and practice of vibration analysis in electronic packages. *MATEC Web of Conferences*, Vol. 182, pp. 02015. DOI: 10.1051/mateconf/201818202015
- [5] Lall P., Gupta P. and Goebel K. (2011) Identification of failure modes in portable electronics subjected to mechanical-shock using supervised learning of damage progression. *2011 IEEE 61st Electronic Components and Technology Conference (ECTC)*. DOI: 10.1109/ectc.2011.5898783
- [6] Kovtun I., Boiko J. and Petrashchuk S. (2017) Nondestructive strength diagnostics of solder joints on printed circuit boards. *2017 International Conference on Information and Telecommunication Technologies and Radio Electronics (UkrMiCo)*. DOI: 10.1109/ukrmico.2017.8095401
- [7] Viswanadham P. and Singh P. (1998) *Failure Modes and Mechanisms in Electronic Packages*. DOI: 10.1007/978-1-4615-6029-6
- [8] Kühl R.W. (1999) Mechanical stress and deformation of SMT components during temperature cycling and PCB bending. *Soldering & Surface Mount Technology*, Vol. 11, Iss. 2, pp. 35-41. DOI: 10.1108/09540919910265677
- [9] Royzman V. (2002) Ways to improve strength reliability of electronics elements and systems. *Modern Problems of Radio Engineering, Telecommunications and Computer Science (IEEE Cat. No.02EX542)*. DOI: 10.1109/tcset.2002.1015917
- [10] Bauriene G., Kovtun I., Boiko J., Petrashchuk S. and Pilkauskas K. (2017) Effects of the strain transmission from the main board to the installed electronic components. *Mechanics*, Vol. 22, Iss. 6. DOI: 10.5755/j01.mech.22.6.16891
- [11] Bansal A., Ramakrishna G. and Liu K. (2011) Method for early detection of PCB bending induced pad cratering. *2011 IEEE 61st Electronic Components and Technology Conference (ECTC)*. DOI: 10.1109/ectc.2011.5898672
- [12] Zahedi F. and Huang H. (2014) A wireless acoustic emission sensor remotely powered by light. *Smart Materials and Structures*, Vol. 23, Iss. 3, pp. 035003. DOI: 10.1088/0964-1726/23/3/035003
- [13] Ralph W.C., Daspt G.L., Cain A.W., Benedetto E.E., Jenkins R.S., Allen A.M. and Newman K. (2013) Acoustic emission detection of BGA components in spherical bend. *2013 IEEE 63rd Electronic Components and Technology Conference*. DOI: 10.1109/ectc.2013.6575573
- [14] Kusiak A. and Kurasek C. (2001) Data mining of printed-circuit board defects. *IEEE Transactions on Robotics and Automation*, Vol. 17, Iss. 2, pp. 191-196. DOI: 10.1109/70.928564
- [15] Prashanth M.D. (2018) *Vibration analysis of printed circuit boards: Effect of boundary condition*. DOI: 10.1063/1.5029594
- [16] Boiko J., Kovtun I. and Petrashchuk S. (2017) Vibration transmission in electronic packages having structurally complex design. *2017 IEEE First Ukraine Conference on Electrical and Computer Engineering (UKRCON)*. DOI: 10.1109/ukrcon.2017.8100294
- [17] Samavatian M., Ilyashenko L.K., Surendar A., Maseleno A. and Samavatian V. (2018) Effects of System Design on Fatigue Life of Solder Joints in BGA Packages Under Vibration at Random Frequencies. *Journal of Electronic Materials*, Vol. 47, Iss. 11, pp. 6781-6790. DOI: 10.1007/s11664-018-6600-3
- [18] Choi U., Blaabjerg F., Jorgensen S., Munk-Nielsen S. and Rannestad B. (2017) Reliability Improvement of Power Converters by Means of Condition Monitoring of IGBT Modules. *IEEE Transactions on Power Electronics*, Vol. 32, Iss. 10, pp. 7990-7997. DOI: 10.1109/tpe.2016.2633578
- [19] Jannoun M., Aoues Y., Pagnacco E., Pougnet P. and El-Hami A. (2017) Probabilistic fatigue damage estimation of embedded electronic solder joints under random vibration. *Microelectronics Reliability*, Vol. 78, pp. 249-257. DOI: 10.1016/j.microrel.2017.08.005
- [20] Xia J., Cheng L., Li G. and Li B. (2017) Reliability study of package-on-package stacking assembly under vibration loading. *Microelectronics Reliability*, Vol. 78, pp. 285-293. DOI: 10.1016/j.microrel.2017.09.012
- [21] Liu F. and Fan R. (2013) Experimental modal analysis and random vibration simulation of printed circuit board assembly. *Advances in vibration engineering*, Vol. 12, No 5, pp. 489-498.
- [22] Xie H., Zhou D. and Liu Z. (2012) The sub-model method for analysis of BGA joint stress and strain during random vibration loading. *2012 13th International Conference on Electronic Packaging Technology & High Density Packaging*. DOI: 10.1109/icept-hdp.2012.6474825
- [23] Qi X., Zhou B. and En Y. (2011) Effect of solder joint parameter on vibration fatigue reliability of high density PCB assembly. *2011 International Conference on Quality, Reliability, Risk, Maintenance, and Safety Engineering*. DOI: 10.1109/icqr2mse.2011.5976665
- [24] Salahouelhadj A., Martiny M., Mercier S., Bodin L., Manteigas D. and Stephan B. (2014) Reliability of thermally stressed rigid-flex printed circuit boards for High Density Interconnect applications. *Microelectronics Reliability*, Vol. 54, Iss. 1, pp. 204-213. DOI: 10.1016/j.microrel.2013.08.005
- [25] Tonolini F., Sala A. and Villa G. (1987) General review of developments in Acoustic Emission methods. *International Journal of Pressure Vessels and Piping*, Vol. 28, Iss. 1-5, pp. 179-201. DOI: 10.1016/0308-0161(87)90075-5

- [26] Bogorosh A., Voronov S., Višniakov N., Ščekaturovienė D. and Bubulis A. (2010) The Mechanism of Defects Formation in Silicon Substrates. *Solid State Phenomena*, Vol. 165, pp. 7-12. DOI: 10.4028/www.scientific.net/ssp.165.7
- [27] Ralph W.C., Benedetto E.E., Allen A.M. and Newman K. (2014) Pad crater detection using acoustic waveform analysis. *2014 IEEE 64th Electronic Components and Technology Conference (ECTC)*. DOI: 10.1109/ectc.2014.6897482
- [28] Bogorosh A., Voronov S., Roizman V., Bubulis A., Vyšniauskienė Ž. (2009) Defect diagnostics in devices via acoustic emission. *Journal of Vibroengineering*, 11(4), pp. 676-683. <https://www.jvejournal.com/article/10343/abs>
- [29] Ralph W.C., Daspit G.L., Cain A.W., Benedetto E.E., Jenkins R.S., Allen A.M. and Newman K. (2013) Acoustic emission detection of BGA components in spherical bend. *2013 IEEE 63rd Electronic Components and Technology Conference*. DOI: 10.1109/ectc.2013.6575573
- [30] Robertson C. (2003) *Printed Circuit Board Designer's Reference: Basics*, Prentice Hall.
- [31] Wei H. and Xu L. (2017) *Research on dynamic model of printed circuit board based on finite element method*. DOI: 10.1063/1.4992899

Підвищення надійності друкованих плат шляхом розробки методів технічної діагностики паяних з'єднань з використанням методу акустичної емісії

Ковтун І. І., Бойко Ю. М., Петрашук С. А.

Стаття присвячується розробці методики технічної діагностики друкованих плат, зокрема їх паяних з'єднань, виконаних за технологією наскрізного і поверхневого монтажу. Експлуатація та технологія викликають механічні взаємодії і сили між підкладкою друкованої плати і електронними компонентами. Такі сили розтягування, зсуву, згину або кручення передаються через контактні з'єднання, які виявляються найбільш слабкими ланками в збірці. Експериментальні дослідження проводилися за допомогою механічних випробувань на розтяг і згин з подальшим використанням методу акустичної емісії. Продемонстрована значна чутливість і застосовність методу акустичної емісії для виявлення дефектів і оцінки граничної міцності паяних з'єднань при неруйнівній діагностиці. Для мінімізації помилок при вимірі малих навантажень при випробуваннях на розтяг керамічних конденсаторів було розроблено спеціальне пристосування. Експериментальні дослідження при випробуваннях на розтяг підтвердили ефект створення перегрівом на паяні з'єднання, оскільки перегрів паяних з'єднань покращує їх адгезію до контактних площадок і збільшує їх міцність на розтяг, і продемонстрували застосовність методу акустичної емісії здатного виявляти значну відмінність між холодним припоем і перегрітим паяним з'єднанням. Пристрій для чистого згину було розроблено для забезпечення одночасного контролю всіх паяних з'єднань при рівномірному випробувальному напруженні. За проведеними випробуваннями по пульсуючому циклу загальний рахунок був визначений як найбільш інформативний параметр

акустичної емісії, який корелює з типами дефектів і граничною міцністю паяних з'єднань. Модель планарної локації розроблена на основі ідеї дистанційного виявлення акустичної емісії через об'єм однорідного середовища, на відміну від поверхні друкованої плати, де сигнал акустичної емісії може бути спотворений або навіть втрачений. Використання методу акустичної емісії і механічного випробування на циклічний згин дозволило розробити метод технічної діагностики паяних з'єднань. Результати, представлені в статті, сприяють удосконаленню технології та конструювання виробів радіоелектроніки.

Ключові слова: паяний шар; друкована плата; технічна діагностика; електронні компоненти; акустична емісія; випробування на розтяг; чистий згин

Повышение надежности печатных плат путем разработки методов технической диагностики паяных соединений с использованием метода акустической эмиссии

Ковтун И. И., Бойко Ю. Н., Петрашук С. А.

Статья посвящается разработке методики технической диагностики печатных плат, в частности их паяных соединений, выполненных по технологии сквозного и поверхностного монтажа. Эксплуатация и технология вызывают механические взаимодействия и силы между подложкой печатной платы и электронными компонентами. Такие силы растяжения, сдвига, изгиба или кручения передаются через контактные соединения, которые выявляются наиболее слабыми звеньями в сборке. Экспериментальные исследования проводились с помощью механических испытаний на растяжение и изгиб с последующим использованием метода акустической эмиссии. Продемонстрирована значительная чувствительность и применимость метода акустической эмиссии для выявления дефектов и оценки предельной прочности паяных соединений при неразрушающей диагностике. Для минимизации ошибок при измерении малых нагрузок при испытаниях на растяжение керамических конденсаторов было разработано специальное приспособление. Экспериментальные исследования при испытаниях на растяжение подтвердили эффект, производимый перегревом на паяные соединения, поскольку перегрев паяных соединений улучшает их адгезию к контактными площадкам и увеличивает их прочность на растяжение, и продемонстрировали применимость метода акустической эмиссии способного выявлять значительное различие между холодным припоем и перегретым паяным соединением. Устройство для чистого изгиба было разработано для обеспечения одновременного контроля всех паяных соединений при равномерном испытательном напряжении. По проведенным испытаниям по пульсирующему циклу общий счет был определен как наиболее информативный параметр акустической эмиссии, который коррелирует с типами дефектов и предельной прочностью паяных соединений. Модель планарной локации разработана на основе идеи дистанционного обнаружения акустической эмиссии через объем однородной среды, в отличие от поверхности печатной платы, где сигнал акустической эмиссии может быть искажен или даже потерян. Использование метода акустической

эмиссии и механического испытания на циклический изгиб позволило разработать метод технической диагностики паяных соединений. Результаты, представленные в статье, способствуют совершенствованию технологии и конструирования изделий радиоэлектроники.

Ключевые слова: паяное соединение; печатная плата; техническая диагностика; электронный компонент; акустическая эмиссия; испытание на растяжение; чистый изгиб