

621.396.96:551.501.815

# Recognition of Atmospheric Formations by Adaptive Lattice Filter' Parameters

Atamanskiy D. V.<sup>1</sup>, Riabukha V. P.<sup>2</sup>, Voitovich O. A.<sup>3</sup>, Semeniaka A. V.<sup>2</sup>,  
Romanenko I. O.<sup>1</sup>, Prokopenko L. V.<sup>1</sup>

<sup>1</sup>Ivan Kozhedub Kharkiv University of Air Force, Kharkiv, Ukraine

<sup>2</sup>Kvant Radar Systems Scientific Research Institute, Kyiv, Ukraine

<sup>3</sup>O. Ya. Usikov Institute for Radiophysics and Electronics National Academy of Sciences of Ukraine, Kharkiv, Ukraine

E-mail: [ataman-19651@ukr.net](mailto:ataman-19651@ukr.net), [regul1984@ukr.net](mailto:regul1984@ukr.net)

The paper deals with algorithms for recognizing atmospheric formations with various coherence meteorological radars. It shows that the known recognition algorithms differ in the degree of complexity, and in the completeness of the vector of phenomena and meteorological formation (MF) types to be recognized. Besides, no single structural and algorithmic basis that allows unifying the measurement and recognition problems. To solve this problem, we propose to use the parameters of adaptive lattice filters (ALF), obtained at a stage of ALF tuning with the help of radar returns from MFs. The proposed algorithm is tested using an annual cycle of experimental data on the amplitude fluctuations of incoherent 3-cm radiowave signals reflected from different cloud types. The recognition statistical characteristics obtained with known and proposed methods are compared. It is demonstrated that the proposed way is practically not inferior to the known ones in terms of the accuracy of recognition of returns from MF but it is directly realized while measuring the amplitude fluctuations spectrum of the returns, and this favorably distinguishes it from the others. The tests confirmed the proposed algorithm effectiveness. A unified structural and algorithmic basis for practical realization of the ALF-based measurements of MF parameters and for recognition of dangerous meteorological phenomena is proposed. We show that the proposed algorithm and its practical implementation can, with minor changes, be used in coherent and incoherent radars, as well as in meteorological channels of non-meteorological radars.

*Keywords:* meteorological radar; turbulence; recognition meteorological formations; adaptive lattice filter; non-energy parameters; correlation coefficient; order of autoregressive process

DOI: [10.20535/RADAP.2022.88.15-23](https://doi.org/10.20535/RADAP.2022.88.15-23)

## Introduction and statement of the problem

A meteorological radar (MR) now is a tool for the prompt detection of dangerous weather phenomena (cumulonimbus clouds, heavy rains, thunderstorms, hail) and for recognition of classes of meteorological formations (MF). This allows to significantly reducing the probability of aircraft accidents in adverse weather conditions and decreasing losses due to dangerous and natural weather phenomena [1–8]. Modern meteorological networks are mainly equipped with two-frequency radar systems based on the cm- and mm- MRs operating at the coherent and polarization modes [1, 9]. Nowadays it is possible to implement the complete dual polarization (for transmission and reception) [10–12]. A list of natural hazards that can be timely detected and diagnosed for further development and movement is, therefore, greatly expanded [1, 2, 10–12].

Methods for recognizing a number of dangerous phenomena (hail, squalls, heavy rainfall, tornado, dust

storm, accumulation of birds and insects) keep to be improved [3, 11–17]. Achievements of related sciences and even industries (fuzzy logic algorithms, artificial intelligence and neural networks [17], joint statistical processing of satellite images and MR data [3], etc.) are involved for this.

However, the MR-based methods for measuring primary parameters of returns from MF remain the same. It is still required to estimate the Doppler spectrum moments [22] and modes [1, 18–21]. To generate a map of hazardous weather phenomena, the maps of distribution of radar reflectivity and upper boundary of cloudness, based on recognition algorithms developed as early as for incoherent MRs, are used [23]. They still show good results. The maps form on the basis of results of measurements of the power of returns from MF. Main difficulties in measuring this parameter are in the large range of variation of the return power and the great spatial variability. This imposes strict requirements on the dynamic range of radar receiver. It is reasonable, therefore, to apply the algorithms that use non-energy parameters for recognition.

Due to the complexity of polarization structure transformation of the probing signal passing through the hydrometeor medium, the measurement results interpretation and accuracy are of particular importance [8]. In particular, estimation of the cross correlation coefficient of signal polarization components opens up great possibilities in the field of distinguishing many meteorological phenomena.

However, the difference between values of the coefficient for some meteorological phenomena is a few hundredths of a percent, and high-quality equipment is required for such fine measurements. In general, the stable identification of meteorological target by this parameter and some other parameters is very difficult [8]. There are often proposed, therefore, such new recognition methods that are based on known spectrum parameter estimates of returns from MF [18–21]. However they do not consider issues of practical implementation of the algorithms.

The structural and algorithmic basis of adaptive lattice filters (ALF) gives great possibilities for their solution [24–30].

**The article objective** is to justify the method for recognition of meteorological formations based on adaptive lattice filter parameters' estimates, which differs from the known ones by simpler implementation and is not inferior to them in the recognition accuracy.

## 1 Measurements of meteorological formation parameters by adaptive lattice filter parameters

A. Lattice filters (LF) described in [24–30] belong to a wide class of multistage filters constructed by the factorized (multiplicative) representation of their matrix impulse response (MIR)  $\mathbf{W}$ , i.e. by the product

$$\mathbf{W} = [\mathbf{H}^*, \mathbf{N}]^* = \mathbf{W}_M \cdot \mathbf{W}_{M-1} \cdot \dots \cdot \mathbf{W}_2 \cdot \mathbf{W}_1, \quad (1a)$$

of sparsely filled in matrices-multipliers  $\mathbf{W}_m$  ( $m \in 1, M$ ). Here the "\*" is the Hermitian conjugation symbol;  $\mathbf{W}$  is the  $2M \times M$  LF MIR  $\mathbf{W}$  composed of the lower  $\mathbf{H} = [h_{il}]_{i,l=1}^M$  and upper  $\mathbf{N}^* = [n_{il}^*]_{i,l=1}^M$  triangular ( $h_{il} = n_{li}^* = 0$  at  $l > i$ )  $M \times M$  Kholetsky decomposition matrices, whereas its multipliers

$$\mathbf{W}_1 = \mathbf{V} \cdot \mathbf{S}_1, \quad \mathbf{S}_1 = \text{diag} [s_1(l)]_{l=1}^M, \quad (1b)$$

$$\mathbf{W}_m = \begin{bmatrix} \mathbf{I}_{m-1} & & \mathbf{0} \\ & \mathbf{E}_m & \\ \mathbf{0} & & \mathbf{I}_{m-1} \end{bmatrix}, \quad m \in 2, M \quad (1c)$$

are  $2M \times M$  (1b) and  $2M \times 2M$  (1c) sparse (with a large number of zero elements) block-diagonal

matrices. In particular, the first stage MIR  $\mathbf{W}_1$  is the product of the  $M \times M$  diagonal matrix  $\mathbf{S}_1$  and the  $2M \times M$  "bifurcation" matrix  $\mathbf{V} = \mathbf{I}_M \otimes [1, 1]^T$  ( $\otimes$  is the Kronecker multiplication symbol), and the MIR  $\mathbf{W}_m$  ( $m \in 2, M$ ) of the rest of stages contains two  $(m-1)$ -dimensional identity matrices  $\mathbf{I}_{m-1}$  and  $2(M-m+1)$ -dimensional block-diagonal matrices

$$\mathbf{E}_m = \text{diag} [\mathbf{E}_m(\ell)]_{\ell=1}^{M-m+1}, \quad m \in 1, M \quad (1d)$$

with the  $2 \times 2$  matrix-blocks

$$\mathbf{E}_m(\ell) = \mathbf{S}_m(\ell) \cdot \mathbf{B}_m(\ell), \quad (1e)$$

$$\mathbf{S}_m(\ell) = \begin{bmatrix} s_m(\ell) & 0 \\ 0 & c_m(\ell) \end{bmatrix}, \quad \mathbf{B}_m(\ell) = \begin{bmatrix} \alpha_m(\ell) & 1 \\ 1 & \beta_m(\ell) \end{bmatrix}. \quad (1f)$$

Herewith, the LF MIR  $\mathbf{W}$  (1a) is constructed of a set of one-type "elementary"  $2 \times 2$  blocks  $\mathbf{E}_m(l)$  ( $m \in 2, M; l \in 1, M-m+1$ ) (1e), which have the meaning of "elementary" lattice filters' (ELF) MIRs, and LF as a whole consists of a set of one-type ELFs, i.e. it has a systolic structure. Fig. 1 shows an example of the  $M=4$ -input LF (Fig. 1, a) and its ELF (Fig. 1, b).

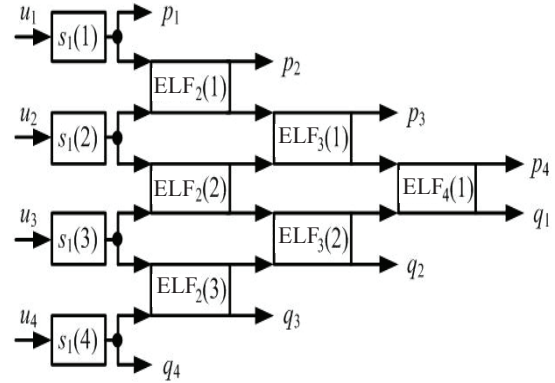

(a)

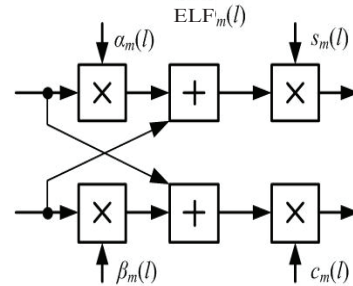

(b)

Fig. 1. The  $M=4$ -input lattice filter (a) and ELF (b)

Thus, the set of ELF parameters  $s_1(\ell)$  ( $\ell \in 1, M$ ) (1b) and  $s_m(\ell)$ ,  $c_m(\ell)$ ,  $\alpha_m(\ell)$ ,  $\beta_m(\ell)$  ( $m \in 2, M$ ;  $\ell \in 1, M - m + 1$ ) (1f) completely determines representation (1a) called the "generalized Levinson factorization" of the multipliers of "upper-lower" and "lower-upper" triangular decompositions of the inverse matrix

$$\Psi = \mathbf{R}^{-1} \quad (2)$$

and exists for any "strictly non-singular" matrices  $\mathbf{R}$ , i.e. matrices with nonzero principal minors of all the orders. The diagonal elements of matrices  $\mathbf{S}_m(\ell)$  in this case are finite, and the matrix  $\mathbf{B}_m(\ell)$  is nondegenerate, so [25]

$$\begin{aligned} \alpha_m(\ell) \cdot \beta_m(\ell) &\neq 1, \\ m \in 2, M; \ell \in 1, M - m + 1. \end{aligned} \quad (3)$$

The most interesting case is when the  $M \times M$  matrix  $\mathbf{R}$  is a correlation matrix (CM) and, therefore, it is Hermitian and positively defined. The following expressions are valid for it

$$\begin{aligned} \alpha_m(\ell) \cdot \beta_m(\ell) &< 1, \\ m \in 2, M, \ell \in 1, M - m + 1, \end{aligned} \quad (4a)$$

$$\begin{aligned} \beta_m(\ell) &= \alpha_m^*(\ell), \\ c_m(\ell) = s_m(\ell) &= \left(1 - |\alpha_m(\ell)|^2\right)^{-1/2}, \end{aligned} \quad (4b)$$

which show a noticeable decrease in the number of parameters defining the LF MIR  $\mathbf{W}$ .

Under conditions of a priori uncertainty (ignorance of true CM  $\mathbf{R}$ ), parameters (4) are unknown and replaced by their estimates that are formed as a result of processing the training sample  $\mathbf{Y}$ . With respect to the considered problem, such a sample contains a set of vectors of readings being a mixture of the receiver internal noise and returns from MF. Lattice filters with such estimates are called adaptive LF (ALF), and the process of their formation is called tuning. For tuning ALF, the algorithms, given, e.g., in [26,27], can be used.

**B.** A general physical meaning of ALF parameters (4) is discussed in detail in [25] and is reduced to the fact that the coefficients  $\alpha_m(\ell)$ , which are partial correlation coefficients, must decorrelate the output signals of the  $m$ -th stage  $\ell$ -th ELF with its input signals, and the coefficients  $s_m(\ell)$  must normalize the output signal power to unity. The practical importance of these parameters lies in the information they carry about the processes under analysis, which is obtained as a result of ALF tuning by available sample.

Let us illustrate this on an example of measuring the power spectrum parameters of inter-period fluctuations of returns from MF. Under conditions of identical intervals between sounding pulses generating the Toeplitz CM  $\mathbf{R}$ , information about the average power  $\widehat{\eta}_{av}$  of the mixture of returns from MF and receiver noise in  $M$  periods of  $K$  adjacent range elements

is contained in normalizing multipliers  $s_1$  (4b) already of the first ( $m=1$ ) stage:

$$\widehat{\eta}_{av} = \frac{2tr(\mathbf{A}) - (a_{1,1} + a_{M,M})}{2(M-1)K} = \frac{1}{s_1^2}, \quad (5)$$

where  $tr(\mathbf{A})$  is the trace of square matrix  $\mathbf{A}$ ;  $a_{i,j}$  ( $i, j \in 1, M$ ) are the elements of sampling CM

$$\mathbf{A} = [a_{i,j}]_{i,j=1}^M = \mathbf{Y} \cdot \mathbf{Y}^* = \sum_{i=1}^K \mathbf{y}_i \cdot \mathbf{y}_i^*, \quad (6)$$

obtained from sample  $\mathbf{Y}$ . At arbitrary intervals of sounding, the average power  $\widehat{\eta}_{av}$  is obtained by the expression

$$\widehat{\eta}_{av} = \frac{1}{MK} tr(\mathbf{A}) = \frac{1}{M} \sum_{\ell=1}^M \frac{1}{s_1^2(\ell)}. \quad (7)$$

The correlation coefficient estimate  $\widehat{r}_1$  of adjacent readings of processed mixture, required for measuring the MF mean velocity  $\widehat{V}_r$  and Doppler velocity spectrum width  $\widehat{\sigma}_v$  [4,22], coincides, with an accuracy to a sign, with the partial correlation coefficient  $\alpha_2$  (4) of the second ( $m=2$ ) stage of the "Toeplitz" tuning algorithm ALF [25]

$$\widehat{r}_1 = s_1 \cdot \sum_{i=1}^M a_{i+1,i} = -\alpha_2. \quad (8)$$

In the general case, in the  $n$ -multiple wobbling mode of intervals of sounding (with Hermitian CM  $\mathbf{R}$ ), which is used to extend a unambiguity range for the MF radial velocity measurements, values of parameters (4) estimates  $s_1(\ell)$  ( $\ell \in 1, M$ ) and  $\alpha_2(\ell)$  ( $\ell \in 1, M-1$ ) are combined. The useful information about moments of the power spectrum of returns from MF, extracted from the ALF parameters, is not limited only to its first two stages. There are known ways for applying parameters of its third ( $m=3$ ) stage to the problem of determining the autoregressive process order  $p$  [28].

**C.** To date, not only theory, algorithms and software have been developed for ALF, but also semi-natural and full-scale tests have been successfully conducted [29]. Fig. 2 shows examples of the ALF practical implementation. Fig. 2, a shows the SHARC ADSP-21469 kit, which implements the band MIR ALF under the input process Toeplitz CM conditions [29]. Fig. 2, b shows the MDSEVM16678L kit, which implements the adjusted band MIR ALF [30] being tuned with the  $k=4$ -rank modification algorithm [26,27].

Below we discuss a methodology for recognizing meteorological phenomena (rain, hail, etc.), and different cloud types by ALF parameters.

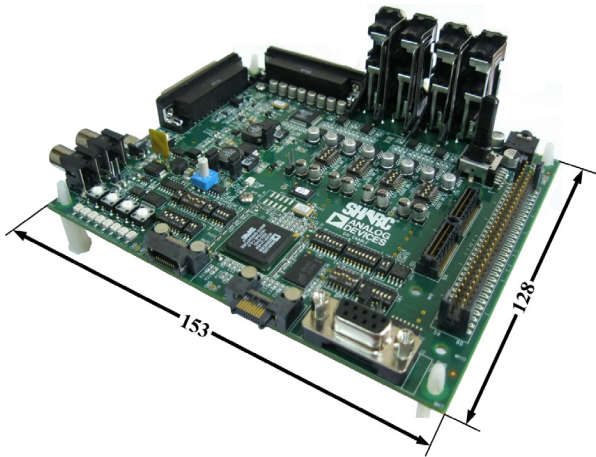

(a)

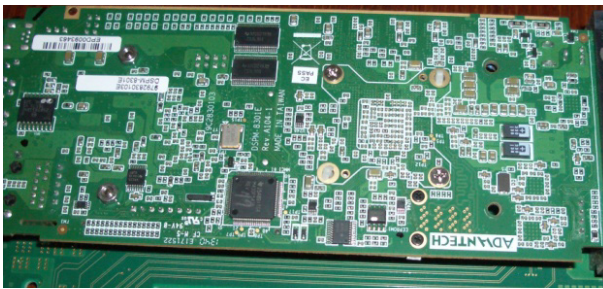

(b)

Fig. 2. Examples of practical implementation of ALF on digital signal processors (DSs) SHARC ADSP-21469 (a) and TMS320C6678 (b)

## 2 Methodology for recognizing meteorological formations by ALF parameters

**A.** *The statement of the problem of MF recognition.* It is assumed that  $G$  MFs, observed as a sequence of  $L$  signal readings  $x_\ell$ ,  $\ell = \overline{1, L}$  in a given finite time interval  $(0, T)$ , are subject to recognition. These readings correspond to the inter-period fluctuations of the intensity of returns from MF in the course of sounding with the pulse radar. The return intensity fluctuations have a random character but their statistical characteristics contain the information about the MF structure. It is assumed that their estimates can be found from accumulated classified samples of the sequences  $x_{\ell, r}^i$  ( $\ell = \overline{1, L}$ ;  $r = \overline{1, n_i}$ ;  $i = \overline{1, G}$ ) for specified MFs.

The recognition procedures may be different, but they are based on comparing some statistics  $\xi$  with a set of this statistics references  $\xi_i$  ( $i \in \overline{1, G}$ ) for each of  $G$  MFs. In [14], the prediction error variance at the output of autoregressive filter serves as such a statistics.

It is promising to compare the quadratic forms  $\xi_i = \alpha^* \widehat{\Psi}_{\alpha_i} \alpha$  ( $i \in \overline{1, G}$ ) of the parameter vector  $\alpha$ , obtained in the course of tuning ALF with matrices  $\widehat{\Psi}_{\alpha_i} = \left( \widehat{\Phi}_{\alpha_i} \right)^{-1}$  that play the role of pre-determined references for  $G$  meteorological phenomena (a bank of "reference" parameter vectors, which correspond to a particular weather situation).

**B.** In the proposed algorithm for recognizing MF, the difference between two modules of the vector  $\alpha$  elements is used as the statistics  $\xi$ :

$$\xi = |\widehat{\alpha}_2| - |\widehat{\alpha}_3|, \quad (9)$$

where  $\widehat{\alpha}_2$ ,  $\widehat{\alpha}_3$  are the estimates of partial correlation coefficients of the ALF second and third stages.

The  $\xi$  value is compared with a set of thresholds  $\xi_i$  ( $i \in \overline{1, G}$ ) of this statistics for all  $G$  MFs. The threshold (reference)  $\xi_i$  of the  $i$ -th MF is understood as an interval of values  $\xi$ , in which a random value of  $\xi$  fits with the 0.9 probability.

The decision whether the received returns belong to those from the  $i$ -th MF ( $i \in \overline{1, G}$ ) is made when the value  $\xi$  is within the interval of acceptable values for this MF. The recognition efficiency is estimated by the probability  $D_p$  of correct recognition of given MF class (type). The results of using the methodology for recognition of cloud types by the data of incoherent radar are considered below.

## 3 Results of experimental studies

**A.** Studies of the effectiveness of algorithms for recognizing MF with radar were carried out using digital records of accumulated samples of sequences of returns (echo signals) for different MFs, received with a radar meter based on a pulsed incoherent meteorological radar of MRL-1 type [13, 15]. The meter incorporates a unit for MRL-1 radar sensitivity calibration, an optical-television boresight for visual observation of the studied objects, and a radar - PC interface unit.

In particular, when studying recognition algorithm (9), we selected the most typical for the Kharkiv region (Ukraine) types of clouds: cirrus (Ci), stratocumulus (Sc), Stratocumulo-nimbus (Sc b), cumulus mediocris (Cu med.), cumulonimbus (Cb), cumulus congestis (Cu cong.).

First, we tested the hypotheses on applicability of the ALF statistics  $\xi$  (9) and parameter  $\alpha_2$  (4) for recognition. For this, we analyzed the distribution functions of statistics  $\xi$  (Fig. 3, b) and parameter  $\alpha_2$  (Fig. 3, a), which are essentially pre-threshold statistics for recognizing turbulence levels in coherent MRs [4, 23]. A significant difference can be seen in the distribution function shape and parameters of the analyzed statistics  $\xi$  and  $\alpha_2$ . The insignificant difference in the ALF  $\alpha_2$ -parameter distribution function (Fig. 3, a)

means that it is inexpedient to use the mentioned parameter in the recognition task. In contrast, a significant shift in the distribution function of the statistics  $\xi$  allows, using the statistics threshold processing, recognizing different types of clouds.

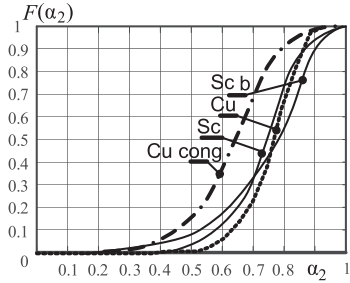

(a)

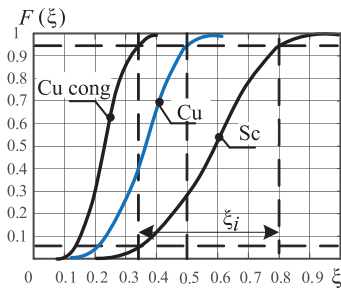

(b)

Fig. 3. Distribution functions of the ALF  $\alpha_2$ -parameter and statistics  $\xi$  for different cloud types in the springtime

The methodology for testing this hypothesis was as follows.

At the first stage, there were determined the thresholds for selected cloud types. For this, the range segment returned pulses were used received from the  $\Delta h = 100$  m thick cloud layer giving the highest power returns, which was located at an altitude of at least 500 m and at a distance no closer than 800 m from MR. Herewith, the influence of clutters from the underlying surface was reduced. For each range cell,  $M = 256$  non-zero readings were used to determine the  $\xi$  value. A set of the obtained values was statistically processed. The estimated distribution functions were used to determine the interval  $\xi_i$  in which random variable  $\xi$  fits with the 0.9 probability (Fig. 4).

The dependence of distribution function on observation period (season) requires a careful approach to determining intervals  $\xi_i$  for each cloud type.

Fig. 5 shows the distribution functions of random variable  $\xi$  for two types of clouds: cirrus that does not produce precipitation, and stratocumulus that can produce precipitation and associated hazards (increased turbulence, lightning, etc.). The significant difference in the distribution function shapes, as well as in the interval  $\xi_i$  position and size is clearly seen. This confirms the feasibility of recognizing MF by

the ALF parameters. In this case, the non-energy parameter  $\xi$  is used as the recognition statistics, which favorably distinguishes the proposed algorithm from the well-known ones based on the analysis of power characteristics of received returns.

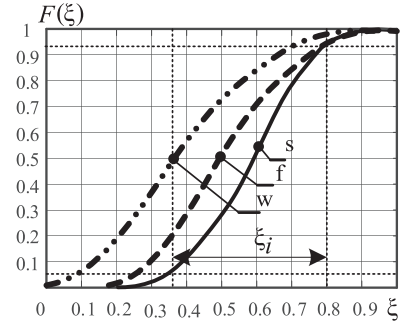

(a)

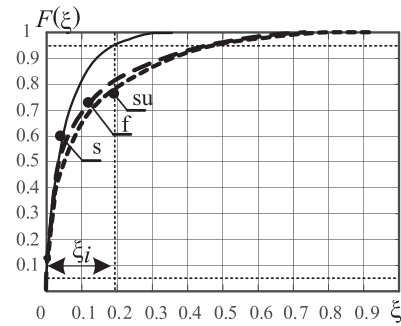

(b)

Fig. 4. Distribution functions of  $\xi$  for cirrus (a) and stratocumulus (b) in spring (s), fall (f), summer (su) and winter (w) seasons

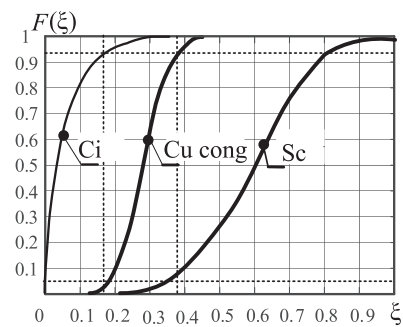

Fig. 5. Distribution functions of  $\xi$  for different cloud types in springtime

Despite the fact that incoherent MRs (IMRs) are obsolete, being replaced by coherent Doppler MRs (CDMRs) everywhere, the potentialities of incoherent radars are not fully exploited. The interest in IMRs is because the methods used in them for detecting and recognizing weather phenomena can be utilized in those radar facilities that are not designed to solve meteorological problems but have the built-in

meteorological channels. As part of the meteorological network, this will provide a significant supplement of meteorological data (reflectivity data) at minimal cost. In addition, incoherent radars can be used for detection of turbulence zones [31]. Below, we discuss the possibility of determining turbulent zones with the ALF-parameters-based IMR.

**B.** Recognition of turbulent zones with IMR is indirectly made by the power of returns from MF [23]. In modern DMR, the decision on how dangerous turbulence is in the observed region is made not by the signal spectrum width  $\sigma_t$  stipulated by the turbulence, but by the kinetic energy dissipation rate  $\varepsilon$  calculated on its basis [6, 8, 32].

Various techniques for the kinetic energy dissipation rate  $\varepsilon$  calculation exist. According to [8], if the external turbulence scale exceeds the resolvable radar volume size, then the following expression is used:

$$\varepsilon = \frac{4 \times 0.72 \sigma_t^3 \sqrt{\ln 2}}{R \theta A^{3/2}}, \quad (10)$$

where  $A$  is the constant usually taken as 1.6;  $R$ ,  $\theta$  are the range to the resolution element and the elevation at which it is observed with MR, respectively.

If the above condition is not met, there is applied the formula

$$\varepsilon = \frac{3.64 \sigma_t^3}{c \tau A^{3/2}} \left( \frac{11}{15} + \frac{0.095 \theta^2}{c \tau \ln 2} \right)^{-3/2}, \quad (11)$$

where  $c \tau$  is the resolution element length.

In [34], the kinetic energy dissipation rate  $\varepsilon$  is calculated according to the expression

$$\varepsilon = \begin{cases} \frac{1.3 \sigma_t^3}{a (1 - \gamma/15)^{2/3}}, & a > b \left( \gamma = 1 - \frac{b^2}{a^2} \right), \text{ a) } \\ \frac{1.3 \sigma_t^3}{b (1 - \gamma/15)^{2/3}}, & a > b \left( \gamma = 1 - \frac{a^2}{b^2} \right), \text{ b) } \end{cases} \quad (12)$$

where  $a$  and  $b$  are the impulse volume sizes in a given range segment. Here,  $a = R \Omega$ ,  $b = c \tau / 2$  where  $R$  is the distance to the range segment, m;  $\Omega = \pi \theta^2 / 4$  is the solid angle of the antenna radiation pattern;  $c$  is the

speed of light,  $\text{ms}^{-1}$ ;  $\tau$  is the probing pulse duration, s;  $\sigma_t$  is the spectrum width of the meteorological particle velocity fluctuations due to the turbulence,  $\text{ms}^{-1}$ ;  $\theta$  is the width of the antenna needle radiation pattern, rad.

A choice of one of them is based on a *priori* data about the turbulence scales inherent in a radar site. Using (12), (10), (11), it is easy to obtain a range of the width  $\sigma_t$  values for each turbulence intensity (Table 1). These formulae give approximately the same results (see Table 1).

Implying a major contribution of  $\sigma_t$  to the final value of the spectrum width  $\sigma_v$  ( $\sigma_t \cong \sigma_v$ ) [33] of MF-microparticles velocity fluctuations, we can obtain intervals for the ALF  $\alpha_2$ -parameters ( $\alpha_2^{\text{inp}}$ ), corresponding to the required turbulence. One characteristic feature of measuring the return spectrum width  $\sigma_v$  should be noted. To ensure the regularity and required accuracy for this parameter measurements, it is accepted to estimate it with signal-to-noise ratio not less than 20 dB [8]. Besides, the spectrum shape should be taken into account and according to it, the level should be chosen at which to measure the width  $\sigma_v$ . At the unimodal Gaussian form of the spectrum, it is equal to 0.8825 of maximum.

The  $\sigma_v$  estimate is related to the correlation coefficient modulus estimate  $|\hat{r}_1(T)|$  of adjacent readings of the mixture of receiver noise and returns from MF as [4, 6]

$$\hat{\sigma}_v = \frac{\lambda}{4\pi T} \sqrt{-2 \cdot \ln(|\hat{r}_1(T)|)}, \quad (13)$$

where  $\lambda$  and  $T$  are the wavelength and repetition period of the MR probing pulses.

As applied to IMR, when measuring the turbulence by signal readings at the output of amplitude detector (AD), it is necessary to recalculate the ALF  $\alpha_2$ -parameter at the input of AD ( $\alpha_2^{\text{inp}}$ ) into the corresponding parameter at the output of AD ( $\alpha_2^{\text{out}}$ ). The corresponding dependences obtained from the mathematical modeling results are shown in Fig. 6.

Табл. 1 Values of  $\sigma_t$  ( $\text{ms}^{-1}$ ) and  $\alpha_2$  at different turbulence intensities ( $\lambda = 3$  cm,  $F_p = 1/T = 600$  Hz,  $\tau = 1$  mcs,  $\theta = 1^\circ$ )

ICAO Turbulence Characteristics	$\varepsilon$ , $\text{m}^2\text{s}^{-3}$ [11]	Formula (11)	Formula (10), (12)	ALF $\alpha_2$ -parameter at the input of AD ( $\alpha_2^{\text{inp}}$ )	ALF $\alpha_2$ -parameter at the output of AD ( $\alpha_2^{\text{out}}$ )
		$\sigma_t$ , $\text{ms}^{-1}$	$\sigma_t$ , $\text{ms}^{-1}$		
light	0–0.01	0–0.78	0–0.8	1 – 0.86	1 – 0.964
moderate	0.01–1	0.78–3.6	0.8–3.75	0.86 – 0.0425	0.964 – 0.452
severe	1–4	3.6–5.7	3.75–5.9	0.0425 – 0.003	0.452 – 0.136
extreme (dangerous)	>4	>5.7	>5.9	< 0.003	< 0.136

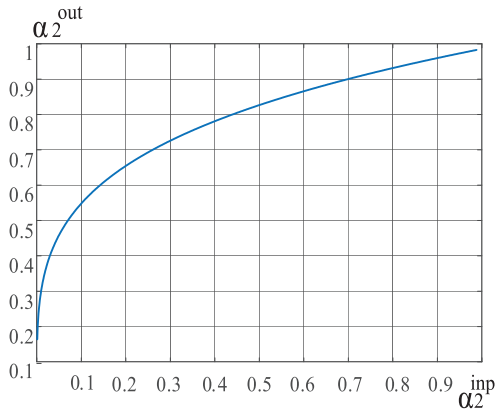

Fig. 6. Relationship between the ALF  $\alpha_2$ -parameter at the AD input and output

It was assumed that the AD output signals  $v_i (i \in 1, M)$  from the resolution element are related to the signals at the receiver output (AD input)  $u_i$  as  $v_i = |u_i|$ .

Calculations show (Table 1) that IMR is capable to detect turbulent regions. However, an accuracy of their localization in space may not meet the requirements, since due to the low repetition of probing pulses, decision (13) is made by small values of correlation coefficient modulus  $|\hat{r}_1(T)|$  of adjacent readings of signal amplitude fluctuations, and hence, by small  $\alpha$ -parameter values. Nevertheless, even under these conditions, the results of determining turbulent zones in atmospheric formations can be acceptable. As an example, Fig. 7 visualizes results of processing atmospheric returns (cumulus congestis (Cu cong.), summer) in IMR (i. 3.A).

Coincidence of dangerous turbulent zones with zones of strong returns from separate MF regions is observed. However, the severest turbulence in a thunderstorm cloud does not coincide with the region that gives the strongest radar return.

This peculiarity is pointed out in [34], and its presence is a good test for the proposed methodology and a confirmation that the amplitude detector under certain conditions may be preferable to the phase detector with the spectral analysis of the output signal [35].

## Conclusion

An algorithm for recognizing meteorological formations (MF) is proposed based on calculation of statistics in the form of difference between the estimate modules of partial correlation coefficients of the adaptive lattice filter (ALF) second and third stages. These values are obtained in the course of ALF tuning by readings of the mixture containing the meteorological radar receiver internal noise and returns from MF. The statistics favorably differs from

the known ones, since it is non-energy parameter and allows simultaneously solving problems of measuring parameters and recognizing MF types and shapes with the use of a single unified software and algorithmic basis for ALF. Practical implementation of the proposed algorithm can be a fruitful supplement and, later, an alternative to the existing common strategy for recognizing weather phenomena in pulsed Doppler meteorological radars.

This enables one to proceed to studying practical features of solving applied problems of MF radar recognition in order to improve the safety of aircraft flights; prevent hail storms, squalls in the "clear sky", etc.

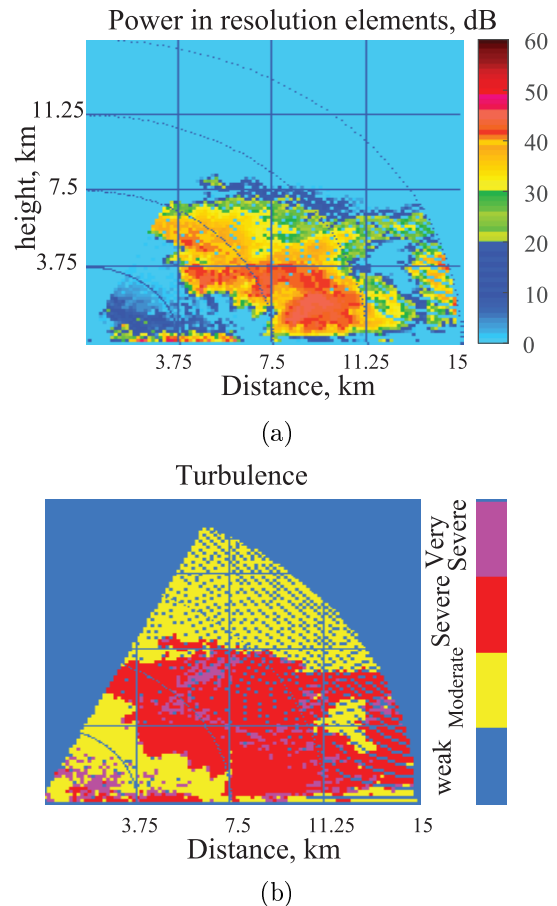

Fig. 7. Visualization of the results of processing returns from MF (Cu cong, summer)

## References

- [1] Kollias P., Bharadwaj N., Clothiaux E. E., et al. (2020). The ARM Radar Network: At the Leading Edge of Cloud and Precipitation Observations. *Bulletin of the American Meteorological Society*, Vol. 101, Iss. 5. DOI: 10.1175/BAMS-D-18-0288.1.
- [2] Dzung Nguyen-Le, Tomohito J. Yamada. (2019). Using Weather Pattern Recognition to Classify and Predict Summertime Heavy Rainfall Occurrence over the Upper Nan River Basin, Northwestern Thailand. *Weather and Forecasting*, Vol. 34, Iss. 2, pp. 345–360. DOI: 10.1175/WAF-D-18-0122.1.



- [3] Qing Meng, Wen Yao, Liangtao Xu. (2019). Development of Lightning Nowcasting and Warning Technique and Its Application. *Advances in Meteorology*, Article ID 2405936. doi:10.1155/2019/2405936.
- [4] Bazlova T. A., Bocharnikov N. V., Brylyov G. B., Solonin A. S., et al., exec. ed. A. S. Solonin. (2015). *Radar meteorological information in aero navigation*. St. Petersburg: Russian State Hydro Meteorological University (RSHMU), 363 p.
- [5] Bolelov E. A. (2018). Meteorological service for civil aviation: problems and ways of their solution. *Civil Aviation High Technologies*, Vol. 21, No. 5, pp. 117-129. doi:10.26467/2079-0619-2018-21-5-117-129. (In Russian)
- [6] Bazlova T. A., et al., ed. by Solonin A. S. (2010). *Radar meteorological observations. V. II: Issues of practical application of the radar meteorological information*. St. Petersburg: Nauka. 517 p.
- [7] Khyong N. V. (2020). Algorithm for detection of meteorological formations by results of primary processing in landing airfield radar. *Proceedings of MPTI*, Vol. 12, No. 2, pp. 117-125.
- [8] Zhukov V. Yu. (2019). Recognition and investigations of dangerous weather phenomena in multiparametric meteorological radar. Thesis for Doctor of phys. and math. sciences degree: 25.00.30 / A. F. Mozhaisky Military Space Academy, St. Petersburg, 312 p. <http://www.rshu.ru/university/dissertations/files/230>.
- [9] Song K., Liu X., Gao T., He B. (2019). Raindrop Size Distribution Retrieval Using Joint Dual-Frequency and Dual-Polarization Microwave Links. *Advances in Meteorology*, Article ID 7251870. DOI: 10.1155/2019/7251870.
- [10] K. Lamer, B. Puigdomènech Treserras, Z. Zhu, B. Isom, N. Bharadwaj, and P. Kollias. (2019). Characterization of shallow oceanic precipitation using profiling and scanning radar observations at the Eastern North Atlantic ARM observatory. *Atmospheric Measurement Techniques*, Vol. 12, Iss. 9, pp. 4931-4947. DOI: 10.5194/AMT-12-4931-2019.
- [11] Zheng X. et al. (2019). Detecting Comma-Shaped Clouds for Severe Weather Forecasting Using Shape and Motion. *IEEE Transactions on Geoscience and Remote Sensing*, Vol. 57, No. 6, pp. 3788-3812. DOI: 10.1109/TGRS.2018.2887206.
- [12] Skripniková K., Rezacová D. (2019). Comparison of Radar-Based Hail Detection Using Single- and Dual-Polarization. *Remote Sensing*, Vol. 11(12), pp. 1436-1448. DOI: 10.3390/rs11121436.
- [13] Naumenko V., Totsky A. V., Khlopov G., Voitovych O., Astola J. T. (2016). Classification of the atmospheric formations by using bicoherence-based features extracted from weather radar backscattering signals. *Telecommunications and Radio Engineering*, Vol. 75(5), pp. 463-475. DOI:10.1615/TelecomRadEng.v75.i5.70.
- [14] Bezruk V. M., Belov E. N., Voitovich O. A., et al. (2011). Radar recognition of meteorological objects by echo-signal fluctuations intensity. *Proc. of IV International Radioelectronic forum "Applied Radioelectronics. State-of-the-art and prospects of development"*, Kharkiv. V.1. 18-21 October 2011, pp. 83-86.
- [15] Voitovich O. A., Zatserklyana A. V., Rudnev G., et al. (2015). Investigations of fluctuations of incoherent signals scattered by clouds. *Radiofizika I elektronika*, Vol. 6(20), No. 2, pp. 48-52.
- [16] Masalov E. V., Krivin N. N. (2019). Precision characteristics of the differential radar reflectivity meter. *Journal of Siberian Federal University. Engineering & Technologies*, Vol. 12(1), pp. 97-105. DOI:10.17516/1999-494X-0028.
- [17] Gagne II D. J., Haupt S. E., Nychka D. W., Thompson G. (2019). Interpretable Deep Learning for Spatial Analysis of Severe Hailstorms. *Monthly Weather Review*, Volume 147, Issue 8, Page(s): 2827-2845. DOI: 10.1175/MWR-D-18-0316.1.
- [18] Wang, X., Wang, J., Miao, C., Zeng K. (2020). Forewarning method of downburst based on feature recognition and extrapolation. *Natural Hazards*, Vol. 103(1), pp. 903-921. DOI: 10.1007/s11069-020-04018-4.
- [19] Kalesse, H., Vogl, T., Paduraru, C., Luke, E. (2019). Development and validation of a supervised machine learning radar Doppler spectra peak-finding algorithm. *Atmospheric Measurement Techniques*, Vol. 12, Iss. 8, pp. 4591-4617. doi:10.5194/amt-12-4591-2019.
- [20] Zhou L., Dong X., Fu Z. et al. (2020). Vertical Distributions of Raindrops and Z-R Relationships Using Microrain Radar and 2-D-Video Distrometer Measurements During the Integrative Monsoon Frontal Rainfall Experiment (IMFRE). *Journal of Geophysical Research*, Vol. 125, Iss. 3. DOI: 10.1029/2019JD031108.
- [21] Qing H., Chu Y., Zhao Z., Su C., Zhou C., and Zhang Y. (2017). Observation and analysis of atmospheric rainfall based on the very high frequency radar. *IET Radar, Sonar & Navigation*, Vol. 11, Iss. 4, pp. 616-620. doi:10.1049/iet-rsn.2016.0089.
- [22] Doviak, R. J., and D. S. Zrnić (1993). *Doppler Radar and Weather Observations*. 2nd ed. Academic Press, 562 p.
- [23] The order of applying the automated meteorological radar complex "ASU-MRL" in practice of storm warning and anti-hail protection. Methodological instructions. RD 52.37.XXX-2008. Moscow: Rosgidromet, 2008. 84 p.
- [24] Rachkov D. S., Lekhovytskiy D. I. (2015). Lattice-filter-based unified structure of system for interperiod processing of weather radar signals. *2015 IEEE Radar Conference (RadarCon)*, pp. 1234-1239. DOI: 10.1109/RADAR.2015.7131183.
- [25] Lekhovytskiy D. I., Riabukha V. P., Atamanskiy D. V., Semeniaka A. V., Rachkov D. S. (2021). Lattice filtration theory. Part I: One-dimensional lattice filters. *Telecommunications and Radio Engineering*, Vol. 80, Iss. 5, pp. 41-79. DOI:10.1615/TelecomRadEng.2021039186.
- [26] Lekhovytskiy D. I. (2018). Adaptive lattice filters for systems of space-time processing of non-stationary Gaussian processes. *Radioelectronics and communications systems*, Vol. 61, No. 11, pp. 607-644. DOI: 10.3103/S0735272718110018.
- [27] Lekhovytskiy D. I., Rachkov D. S., Semeniaka A. V. (2015). K-rank modification of adaptive lattice filter parameters. *2015 IEEE Radar Conference (RadarCon)*, pp. 127-132. DOI: 10.1109/radar.2015.7130983.
- [28] Atamanskiy, D. V., Semeniaka, A. V. & Krasnoshapka, I. V. (2021). Width Estimation of Non-Gaussian Doppler Velocity Spectra of Meteorological Formations. *Radioelectronics and Communications Systems*, Vol. 64, pp. 1-13. DOI: 10.3103/S0735272721010015.
- [29] Lekhovytskiy, D. I., Atamanskiy, D. V., Rachkov, D. S., Semeniaka A. V. (2017). Estimation of the energy spectrums of reflections in pulse doppler weather radars.



- Part 3. Statistical analysis of the reconstruction techniques of continuous spectrums of the reflections from meteorological objects. *Radioelectronics and Communications Systems*, Vol. 60, No. 2, pp. 47–79. DOI: 10.3103/S0735272717020017.
- [30] Riabukha V. P., Semeniaka A. V., Katushin E. A., Zari-tskiy V. I., Golovin O. O. (2019). Adaptive lattice filter-based digital adaptive system of radar protection against masking clutters. *Armour and Military Technology*, No. 4 (24), pp. 32-40. DOI: 1034169/2414-0651.2019.3(23).32-40.
- [31] Averyanova Yu. A., Prokopenko I. G., Prokopenko K. I., Yanovsky F. J. (2004). Algorithms of turbulence detection with weather radars. *Proceedings of the NAU [Visnyk NAU]*, Vol. 19, No. 1, pp. 41–51. DOI: 10.18372/2306-1472.19.952. [In Ukrainian].
- [32] Bazlova T. A., Bocharnikov N. V., Brylev G. B. (2002). *Meteorological automated radar networks*, exec. ed. G. B. Brylev, St. Petersburg: Gidrometeoizdat, 332 p.
- [33] Skolnik, W. E. Ed. (2014). *Handbook of radar. Book 1*. Moscow: Tekhnosfera, 672p. [in Russian].
- [34] Recommendations for working with weather radars "Kontur-10Ts" series 5 for flight crews [Rekomendacii po rabote s meteoradiolokatorami «Kontur-10C» seriya 5 dlya letnyh ekipazhej]. <https://www.kontur-niirs.ru/static/documents/97.pdf> (accessed 29/12/20) [In Russian].
- [35] Zhukov V. Yu., Bychkov A. A., Shchukin G. G. (2015). Additional informative capabilities of the small-sized "Contour METEO-01" meteorological radar. *V All-Russian Armand Readings: Ultra-wideband signals in radiolocation, communication and acoustics. Proceedings of the V All-Russian Scientific Conference*, Murom, Russia, 29 June-01 July, pp. 134-139.

## Розпізнавання атмосферних утворень за параметрами адаптивного решітчастого фільтра

*Атаманський Д. В., Рябуха В. П., Войтович О. А., Семеняка А. В., Романенко І. О., Прокопенко Л. В.*

Розглядаються алгоритми розпізнавання атмосферних утворень у метеорологічних радіолокаторах із різною когерентністю. Показується, що відомі алгоритми розпізнавання відрізняються ступенем складності, повнотою вектора явищ і видів метеоутворень. Крім цього, немає єдиної структурно-алгоритмічної основи, що дозволяє уніфікувати завдання вимірювання та розпізнавання. Для вирішення цього завдання пропонується використовувати параметри адаптивних решітчастих фільтрів, що отримуються на етапі їх налаштування за відображенням метеоутворень. Проводиться тестування запропонованого алгоритму за даними річного циклу експериментальних даних флюктуацій амплітуд некогерентних сигналів 3-см діапазону радіохвиль, відбитих від різних видів хмар. Порівнюються статистичні характеристики розпізнавання відомими та запропонованими методами. Показується, що запропонований метод за точністю розпізнавання відбиття від метеоутворень практично не поступається відомому, але реалізується безпосередньо в процесі вимірювання параметрів спектра флюктуацій амплітуд відбиття, що вигідно відрізняє

його від інших. Підтверджується ефективність запропонованого алгоритму розпізнавання. Запропоновано єдину структурно-алгоритмічну основу практичної реалізації вимірювання параметрів метеоутворень та розпізнавання небезпечних метеоявищ на базі адаптивних решітчастих фільтрів. Показується, що запропонований алгоритм та його практична реалізація можуть за незначних змін застосовуватися в когерентних та некогерентних метеорадіолокаторах, а також у метеоканалах неметеорологічних РЛС.

*Ключові слова:* метеорологічний радіолокатор; турбулентність; розпізнавання метеоутворень; адаптивний решітчастий фільтр; неенергетичні параметри; коефіцієнт кореляції; порядок процесу авторегресії

## Распознавание атмосферных образований по параметрам адаптивного решетчатого фильтра

*Атаманский Д. В., Рябуха В. П., Войтович О. А., Семеняка А. В., Романенко И. О., Прокопенко Л. В.*

Рассматриваются алгоритмы распознавания атмосферных образований в метеорологических радиолокаторах с различной когерентностью. Показывается, что известные алгоритмы распознавания отличаются степенью сложности, полнотой вектора распознаваемых явлений и видов метеообразований. Кроме этого, не существует единой структурно-алгоритмической основы, позволяющей унифицировать задачи измерения и распознавания. Для решения этой задачи предлагается использовать параметры адаптивных решетчатых фильтров, получаемые на этапе их настройки по отражениям от метеообразований. Проводится тестирование предложенного алгоритма по данным годичного цикла экспериментальных данных флюктуаций амплитуд некогерентных сигналов 3-см диапазона радиоволн, отраженных от различных видов облаков. Сравниваются статистические характеристики распознавания известными и предлагаемым методами. Показывается, что предлагаемый метод по точности распознавания отражений от метеообразований практически не уступает известному, но реализуется непосредственно в процессе измерения параметров спектра флюктуаций амплитуд отражений, что выгодно отличает его от других. Подтверждается эффективность предложенного алгоритма распознавания. Предложена единая структурно-алгоритмическая основа практической реализации измерения параметров метеообразований и распознавания опасных метеоявлений на базе адаптивных решетчатых фильтров. Показывается, что предложенный алгоритм и его практическая реализация могут при незначительных изменениях применяться в когерентных и некогерентных метеорадиолокаторах, а также в метеоканалах неметеорологических РЛС.

*Ключевые слова:* метеорологический радиолокатор; турбулентность; распознавание метеообразований; адаптивный решетчатый фильтр; неэнергетические параметры; коэффициент корреляции; порядок процесса авторегрессии